

## Training Oscilloscope II

### DEMONSTRATE THE SUPERPOSITION OF MAGNETIC FIELDS IN A VACUUM

- Superposing magnetic fields with the same and different frequencies and observing the displacement of the focused spot on the screen of the tube.
- Generating closed Lissajous figures.
- Checking the frequency of the mains supply.

UE3070850

06/16 JöS

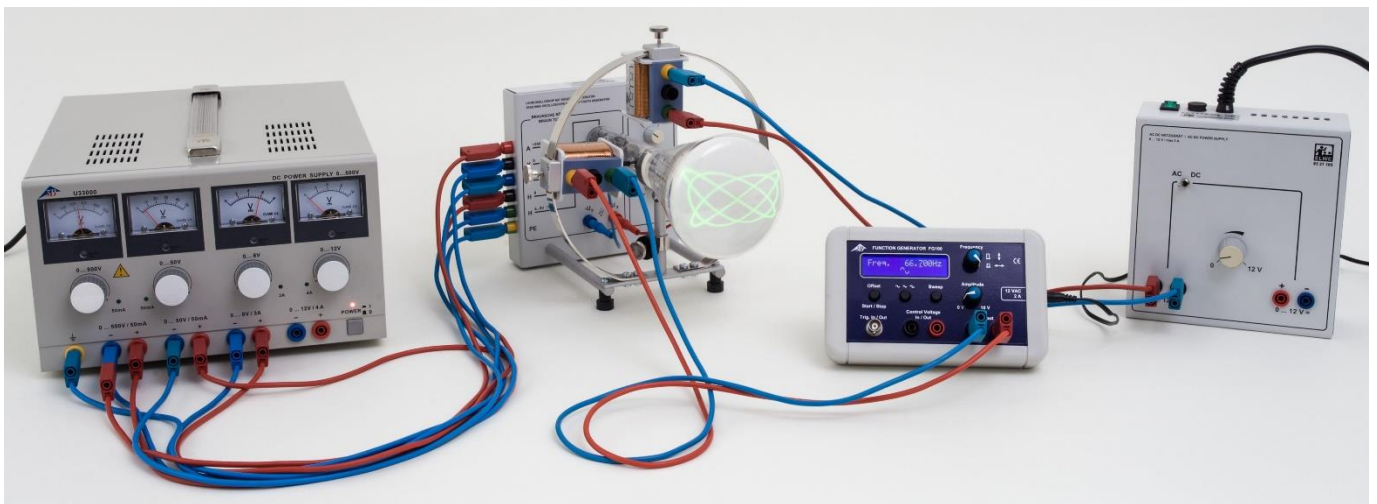

Fig. 1: Experiment set-up.

### GENERAL PRINCIPLES

**A Braun tube can be used to demonstrate the principle of superposition for magnetic fields in a vacuum, by observing the deflection of the beam in the magnetic field. It is especially instructive to also perform experiments with alternating magnetic fields, as the electron beam follows the changes of the magnetic field without a significant time-lag.**

In the experiment, two identical current-carrying coils are placed outside the Braun tube, and the deflection of the electron beam in the magnetic fields of the coils is observed on the tube's fluorescent screen as shifts of the focused spot. The magnetic field of the horizontal coil causes a vertical shift of the beam, while that of the vertical coil causes a horizontal shift.

When an alternating magnetic field at the mains frequency is applied to one of the coils, the focused spot is stretched out to become a vertical or horizontal line. If both coils are then

connected in parallel to the alternating voltage source, the screen shows a straight line at  $45^\circ$  to the vertical, whereas when the coils are connected in opposition the line is at  $-45^\circ$ , as the shifts produced by the two magnetic fields are superposed.

The experiment can be extended to study the effects of alternating magnetic fields of different frequencies. The Lissajous figures that then appear on the screen depend critically on the relationship between the frequencies of the two magnetic fields and on their phase relationship. When the ratio of the frequencies is an integer or a simple fraction, closed figures are generated. Their exact shape also depends on the phase difference between the magnetic fields. As an example, Figure 2 shows Lissajous figures with a frequency ratio 5:1.

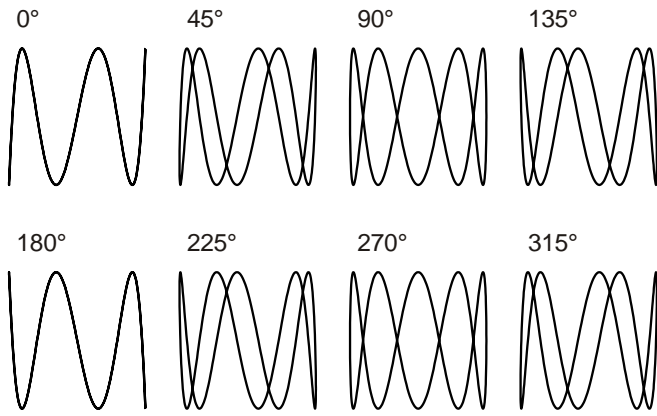

Fig. 2: Lissajous' figures for the frequency ratio 5:1 with phase differences 0°, 45°, 90°, ...

If the frequency ratio is only slightly different from a simple rational value, we observe a closed figure that changes with time, at a rate that becomes slower as the difference from a simple ratio is reduced. In the experiment, this behaviour is used to check the mains frequency. For this, one coil is connected to a transformer working at the mains frequency, while the second coil is connected to a signal generator whose output frequency can be read precisely.

**LIST OF EQUIPMENT**

|    |   |                        |
|----|---|------------------------|
| 1  | Training Oscilloscope                   | 1000902 (U8481350)     |
| 1  | DC Power Supply 0 – 500 V @230V         | 1003308 (U33000-230)   |
| or |   |                        |
| 1  | DC Power Supply 0 – 500 V @115V         | 1003307 (U33000-115)   |
| 1  | Function Generator FG 100 @230V         | 1009957 (U8533600-230) |
| or |   |                        |
| 1  | Function Generator FG 100 @115V         | 1009956 (U8533600-115) |
| 1  | AC/DC Power Supply 0 – 12 V @230V       | 1001007 (U8521105-230) |
| or |   |                        |
| 1  | AC/DC Power Supply 0 – 12 V @115V       | 1001006 (U8521105-115) |
| 1  | Set of 15 Safety Experiment Leads 75 cm | 1002843 (U138021)      |

**SET-UP**

**Safety instructions**

The training oscilloscope is operated with voltages, some of which are above 60 V.

- Always turn off power supply before making connections.
- Use safety leads.

Since the glass tube is evacuated, there is an implosion hazard.

- Do not subject the tube to sharp blows or mechanical stress.

As a rule, the training oscilloscope operates at anode voltages up to about 300 V depending on what tube is connected. The anode voltage must not, however, exceed 350 V.

In schools and training institutions, operation of the device is to be responsibly supervised by trained personnel.

**To start operation**

- Turn off the power supply.
- Connect the inputs of the demonstration oscilloscope to the outputs of the power supply that supply the specified voltages (Fig. 3).
- Turn on the power supply.
- Adjust the voltage so as to not to exceed the limits.
- Turn off the saw-tooth generator.

After 10-30 sec, a green spot appears on the fluorescent screen, which denotes where the electron beam is hitting the screen. In order to keep the tube as simple and clear as possible for educational purposes, it was decided to do without additional apparatus for secondary acceleration and focusing of the beam. For this reason, it is not usually possible to focus the beam to the sharpness seen in conventional oscilloscopes.

- Vary the Wehnelt voltage until the spot reaches its minimum dimensions.

The electron beam is visible as a reddish thread inside the tube, but only in a darkened room because of its low intensity.

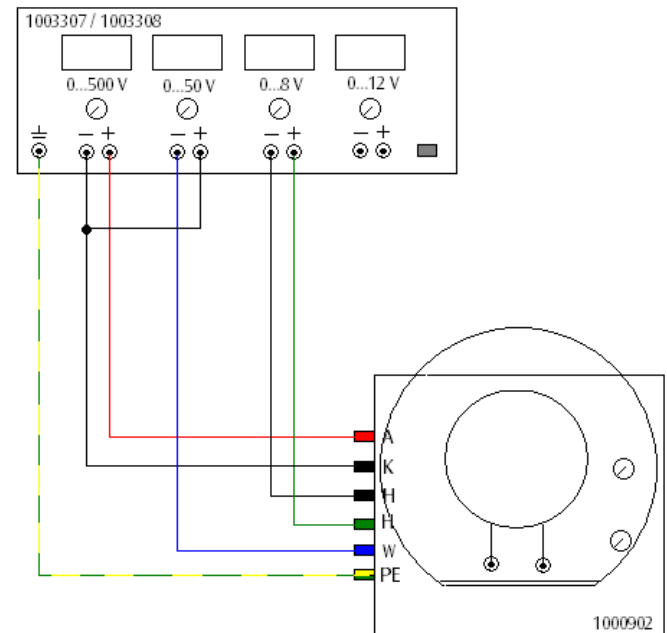

Fig. 3: Connection of training oscilloscope to power supply.

## EXPERIMENT PROCEDURE

### Superposition of alternating magnetic fields

- Attach a coil to the metal ring as shown in Fig. 4 facing inwards and with its axis horizontal.
- Connect the inputs of the coil (green, yellow) to the function generator (set to a sinusoidal voltage at 50 Hz) as shown in Fig. 4. Select an amplitude such that the line which appears on the oscilloscope screen is about half the screen diameter in length.
- Adjust the ring magnet on the tube holder until the line is as far as possible in the centre of the screen and aligned vertically.
- Attach another coil to the metal ring facing inwards with its axis aligned vertically.
- Connect the inputs of the coil (green, yellow) to the AC/DC power supply.
- Turn on the AC/DC power supply and adjust the (AC) voltage until an ellipse appears.
- Set the frequency of the function generator to an integer multiple of the 50 Hz frequency and observe the trace.

### Generation of closed Lissajous figures

- While continuing to superimpose alternating magnetic fields (see above), set the function generator back to 50 Hz until the ellipse reappears.

Depending on how well the frequencies of the input signals are matched, the ellipse will continually deform, whether quickly or slowly. It will do so in a cycle which will twice see the trace take the form of a sloping straight line.

- Adjust the amplitude of the function generator such that these two lines both have a gradient of 45° and during the transition from one to the other, the trace takes the form of a circle.
- Set the frequency of the function generator to an integer multiple of the 50 Hz frequency.

### Checking mains frequency

If the frequency ratio is only slightly different from a simple rational value, we observe a closed figure that changes with time, at a rate that becomes slower as the difference from a simple ratio is reduced. This behaviour can be used to check the mains frequency. For this, one coil is connected to a transformer working at the mains frequency, while the second coil is connected to a function generator from which the output frequency can be read precisely.

To match the mains frequency  $\nu$ , a generator frequency  $\nu_5$  is sought for which the Lissajous figure with a frequency ratio of 5:1 changes most slowly.

## EVALUATION

### Superposition of alternating magnetic fields

Two alternating magnetic fields can be superimposed without difficulty. The cathode ray beam (electron beam) is then deflected by means of two coils mounted vertically and horizontally.

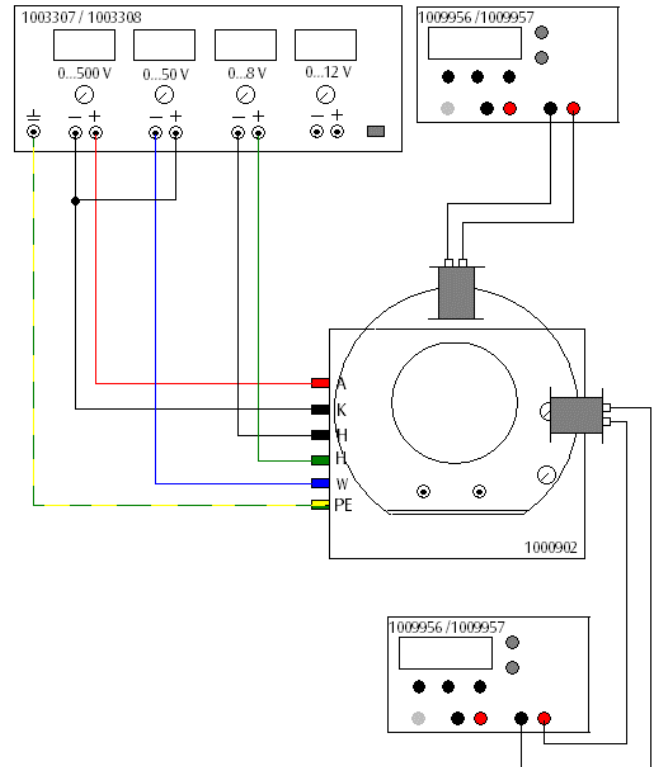

Fig. 4: Positioning and connection of coils.

### Generation of closed Lissajous figures

We are already seeing the simplest Lissajous figures. Their shapes depend on the ratio of the frequencies and on the phase difference. Any slight deviation from the exact frequency desired from the function generator (the inherent inaccuracy arising from the instrument's manufacture is usually enough) automatically results in phase shifting and all the figures associated with a given frequency ratio can be viewed in sequence.

If the frequency of the first function generator is set to an integer multiple of the horizontal frequency (50 Hz), the Lissajous figures associated with frequency ratios 2:1, 3:1, 4:1,... can be seen.

Other Lissajous figures arise for further whole number ratios between the vertical and horizontal frequencies, e.g. 3:2 (75 Hz), 4:3 (66.7 Hz).

### Checking mains frequency

The mains frequency  $\nu$  is calculated to be:

$$(1) \quad \nu = \frac{\nu_5}{5} = \frac{249.95 \text{ Hz}}{5} = 49.99 \text{ Hz} .$$

The measurement has a precision of  $\pm 0.01$  Hz, since  $\nu_5$  can be adjusted with a precision of  $\pm 0.05$  Hz.

