

## Stirling Engine D 1000817

### Instruction manual

11/23 THL/ALF/UD

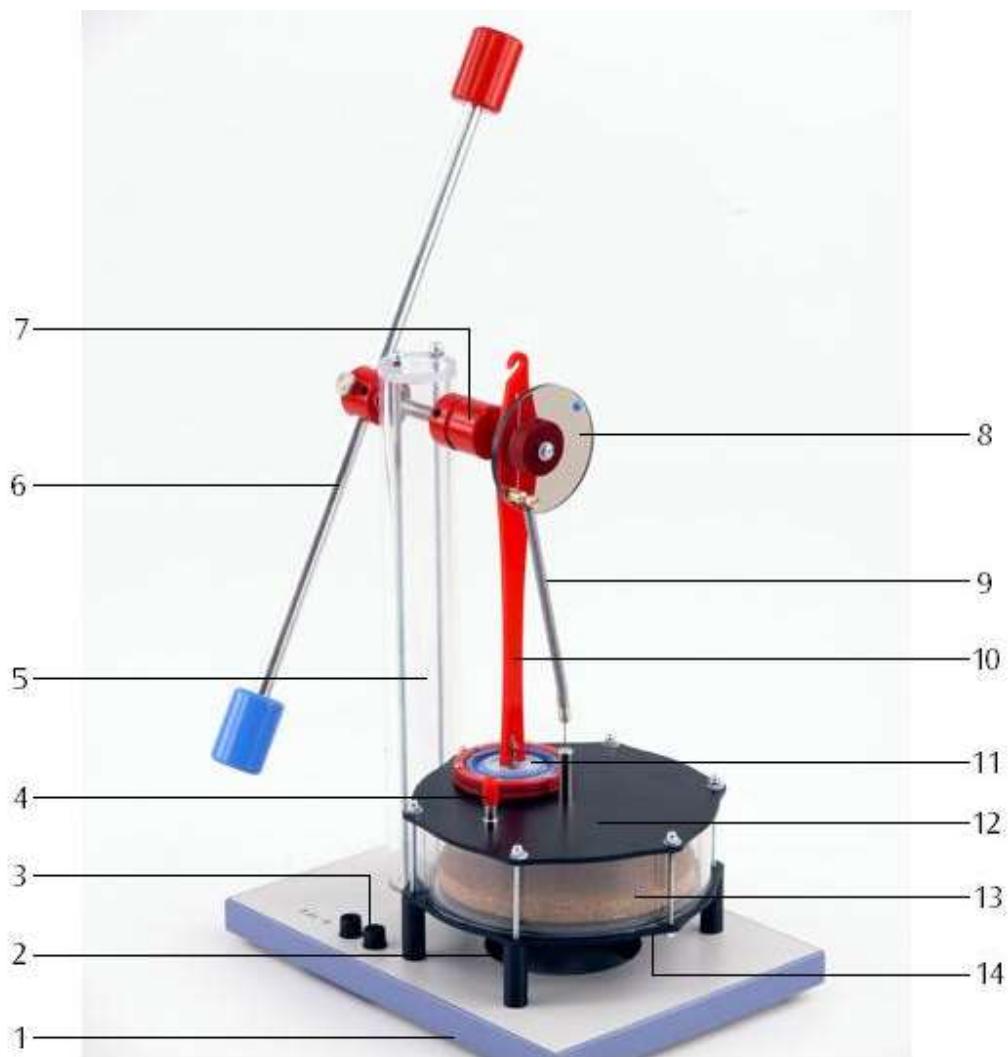

- 1 Base plate
- 2 Hole for tea candle
- 3 Hot plate connector
- 4 Hose nozzle with sealing cap
- 5 Stand
- 6 Rotor with weights
- 7 Eccentric with groove

- 8 Torque disc
- 9 Tension spring
- 10 Connector rod with hook
- 11 Working piston (membrane)
- 12 Upper plate
- 13 Displacement piston
- 14 Lower plate with electric heater

## 1. Safety instructions

When working with naked flames, there is always a risk of fire and injury.

- Take extra care when handling naked flames and molten wax.
- The Stirling engine may not be heated electrically at the same time as it is being heated by a candle. There is a risk of damage to the equipment.
- When operating the Stirling engine using a spotlight or sunlight, it is essential that care be taken not to expose the red plastic components to intense heat.

## 2. Description

The Stirling engine D is a fully functional model, optimised for teaching purposes and intended to demonstrate how thermal energy can be converted to mechanical energy as well as for investigating the Stirling cycle.

The displacement piston moves discontinuously with a delay during heating and cooling of the working medium, air. This emulates the ideal Stirling cycle better than would be the case with a continuously moving piston and also makes for improved efficiency. The motion of the displacement piston is controlled by the torque disc. When heat is supplied from below, either by means of the electric heater or by a candle flame, the displacement piston precedes the working piston (membrane) by about 100°. The optimum angle is technically dependent on the speed of rotation.

Heat can be supplied either by the built-in electric hot plate, a candle or by focussed heat radiation from the sun or by a lamp. The direction of rotation depends on whether the heat is supplied from above or below.

To record pV diagrams, the pressure in the working cylinder can be measured by means of a hose attached to the nozzle provided and the volume can be determined by attaching a thread to the hook on the connecting rod in order to measure the stroke of the working piston.

## 3. Scope of delivery

- 1 D-series Stirling engine 1000817
- 1 Set of transport packaging (foam plastic block, rubber band and retaining rod)

## 4. Accessories

Supplementary set for Stirling engine D (1008516)

The supplementary set for the Stirling engine D provides accessories necessary for constructing sensors. The set consists of the following:

- 1 Base plate for assembly of displacement sensor (1021534)
- 1 Knurled screw for attaching the base plate to the stand
- 1 Stem with a magnetic base for the displacement sensor
- 1 Silicone tube for attaching the relative pressure sensor (1021532)
- 1 Set of threads with suction cup
- 2 Weights with hook, both 20 g

## 5. Technical data

Heater voltage:	8 – 15 V, 1.5 A
Gas volume:	330 cm <sup>3</sup> – 345 cm <sup>3</sup>
Speed:	30 – 100 rpm
Dimensions not including rotor:	260×185×330 mm <sup>3</sup>
Rotor:	400 mm
Weight:	2.2 kg

## 6. Operating principle

The principle of how a Stirling engine works can be divided, in simplified form, into the following four processes:

### Heating:

During the heating phase, the displacement piston (P1) moves upwards so that air is displaced down into the heated part of the displacement cylinder. Temperature and pressure both rise in a fashion that is almost isochoric. The working piston is in its lower rest position (bottom dead centre) at this point (see Fig. 1). The displacement piston moves in advance of the working piston till it reaches its top dead centre position. This is the point where the air is at its lowest volume, but highest temperature and pressure (see Fig. 2).

### Expansion:

The heated air expands almost isothermally, thus

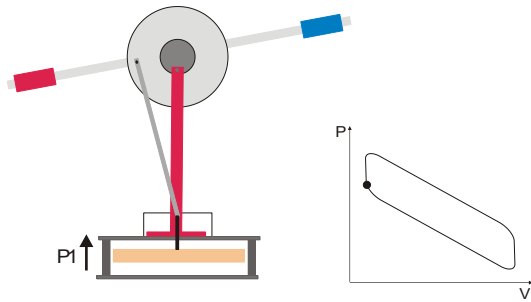

Fig. 1: Heating

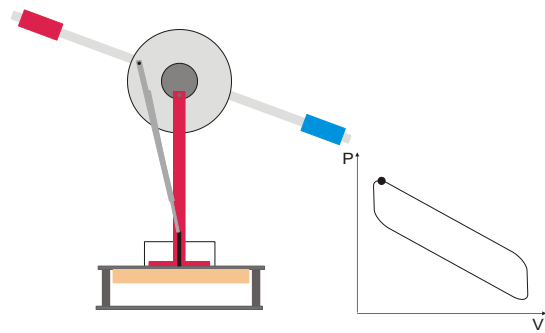

Fig. 2: Heating

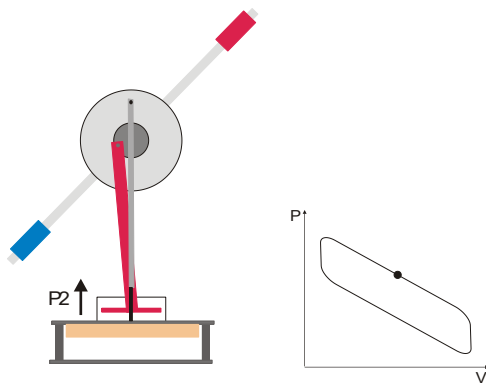

Fig. 3: Expansion

forcing the working piston (P2) upwards. In the process, mechanical work is transferred via the shaft to the rotor. The volume of air increases as the air absorbs heat and the pressure reduces (see Fig. 3).

### Cooling:

Cooling occurs while the working piston is at top dead centre and the displacement piston (P1) is on its downstroke, forcing air to move into the upper part of the displacement cylinder. The air then cools and the upper plate absorbs heat. The displacement piston finally reaches bottom dead centre (see Figs. 4 and 5).

### Compression:

The cooler air is compressed isothermally by the working piston moving downwards. The mechanical work needed for this is supplied by the rotor acting as a flywheel (see Fig. 6).

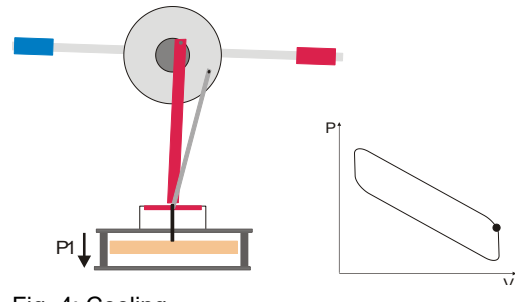

Fig. 4: Cooling

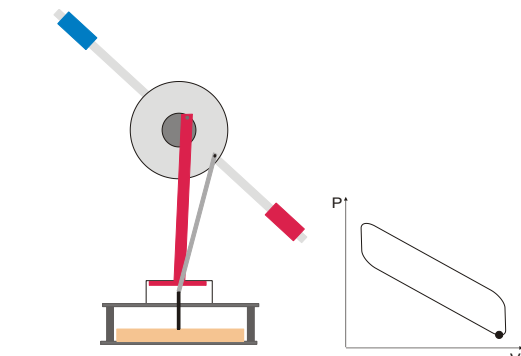

Fig. 5: Cooling

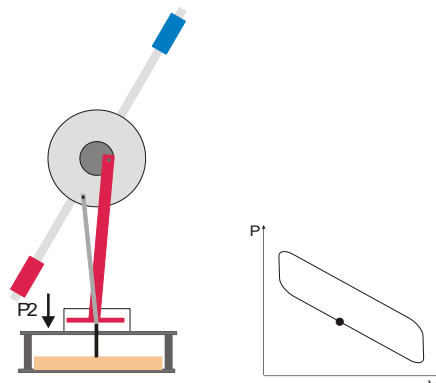

Fig. 6: Compression

## 7. Getting the engine ready for use



Fig. 7: Stirling engine as secured for storage

- Remove the rubber band (3) from the securing hook (4) for the displacement piston and take the hook out of the hose nozzle.
- Seal off the hose nozzle with the red cap (5).
- Remove the foam plastic block (2) between the stand and the rotor weight.
- Undo the securing screw (1), align the rotor horizontally so that it is balanced and tighten the screw back up again.

The engine is then ready for use.

The Stirling engine must not be transported unless the displacement piston is secured.

- To secure it, take the sealing cap of the hose nozzle, put the securing hook back in and secure it in place with the rubber band.
- Secure the rotor as well.

## 8. Operation

### 8.1 Operation as a heat engine

#### 8.1.1 Electric heating

The following power supplies are recommended for heating the Stirling engine electrically:

1 DC power supply @230 V	1003312
or	
1 DC power supply @115 V	1003311

- Connect the power supply to the pair of sockets and set the heater voltage up to 12 V (1.5 A approx.).

- After heating for about one or two minutes, start the engine by pushing the rotor clockwise as seen from the front of the engine.
- If the Stirling engine fails to keep moving of its own accord, wait about a minute longer and push the rotor round again.

The speed of the engine is nearly proportional to the difference in temperature between the top plate and the bottom plate and is thus largely dependent on the heat supplied.

- Reduce the heater voltage in steps down to about 8 V and observe how the speed reduces.

#### 8.1.2 Heating via a candle flame

- Light a tea candle and place it on a heat-resistant mat.
- Place the Stirling engine over the candle so the hole in the middle is over the flame.
- Wait for several minutes until the lower plate has heated up.
- Push the rotor clockwise as seen from the front of the engine.
- If the Stirling engine fails to keep moving of its own accord, wait about a minute longer and push the rotor round again.

#### 8.1.3 Heating via a lamp (spotlight)

- Shine a light on the top plate from about 1 or 2 cm using a lamp with a 60-W bulb and a focussed beam (spotlight). In this case it is the lower plate that will cool the air in the displacement cylinder.
- Alternatively, the upper plate can be heated via sunlight focused using a concave mirror.
- Wait for about 8 to 10 minutes until the upper plate has heated up.
- Push the rotor anti-clockwise as seen from the front of the engine.
- If the Stirling engine fails to keep moving of its own accord, wait about a minute longer and push the rotor round again.

### 8.2 Recording a pV diagram

To record a pV diagram, the following pieces of equipment are also required:

1 Supplementary set for Stirling engine D	1008516
1 DC power supply @230 V	1003312
or	
1 DC power supply @115 V	1003311

- 1 Relative Pressure Sensor FW  $\pm 100$  hPa 1021532
- 1 Displacement Sensor FW 1021534
- 2 Sensor Cables 1021514
- 1 Data logger
- 1 Software

More information about digital measurement can be found on the product's webpage in the 3B Webshop.

- Connect the relative pressure sensor to the hose nozzle using silicone tubing.
- Attach the base plate to the stand using the knurled screw.
- Screw the stem with the magnetic base into the displacement sensor and place it on the base plate.
- Loosen the screw on the displacement sensor's pulley. Wind a thread once around the pulley and lead it out of the recess placing a loop around the screw. Use the screw to fix the thread in place (see Fig. 8).
- Attach one end of the thread to the hook of the connector rod and suspend a weight from the other end.
- Use the suction pad to attach a second thread to the base plate. Thread this over the groove in the eccentric and use the other weight as a load on the free end.

This load ensures that the pV diagram comes out better.

- Connect the power supply to the heater plate and set the voltage up to 12 V (1.5 A approx.).
- Connect both sensors to the data logger.
- Start the software.
- After the Stirling engine has heated up, start it running by pushing the rotor in a clockwise direction.
- Start the measurement and evaluate the data.

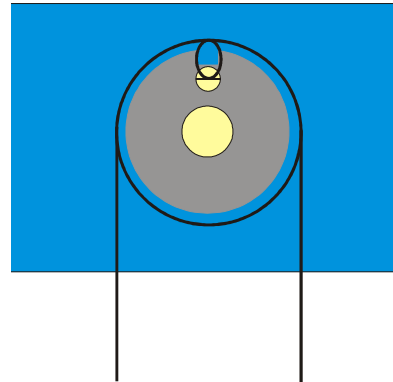

Fig. 8: Schematic illustration of how the thread is wound around the pulley of the displacement sensor

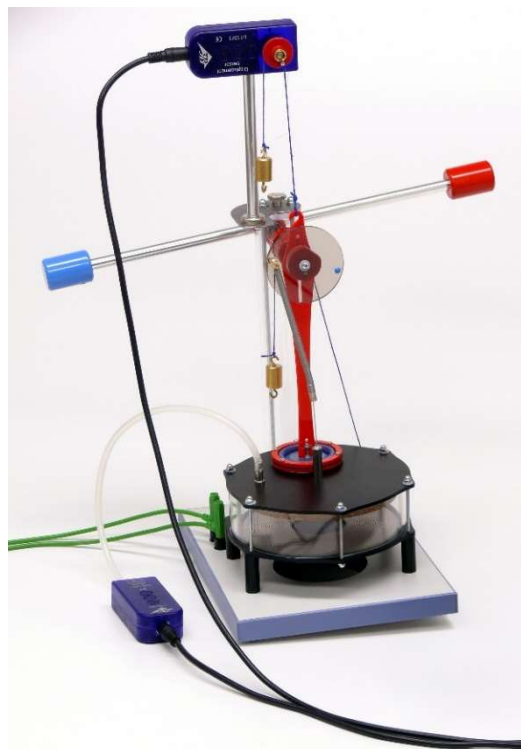

Fig. 9: Stirling engine D with installed sensors for recording the pV diagram

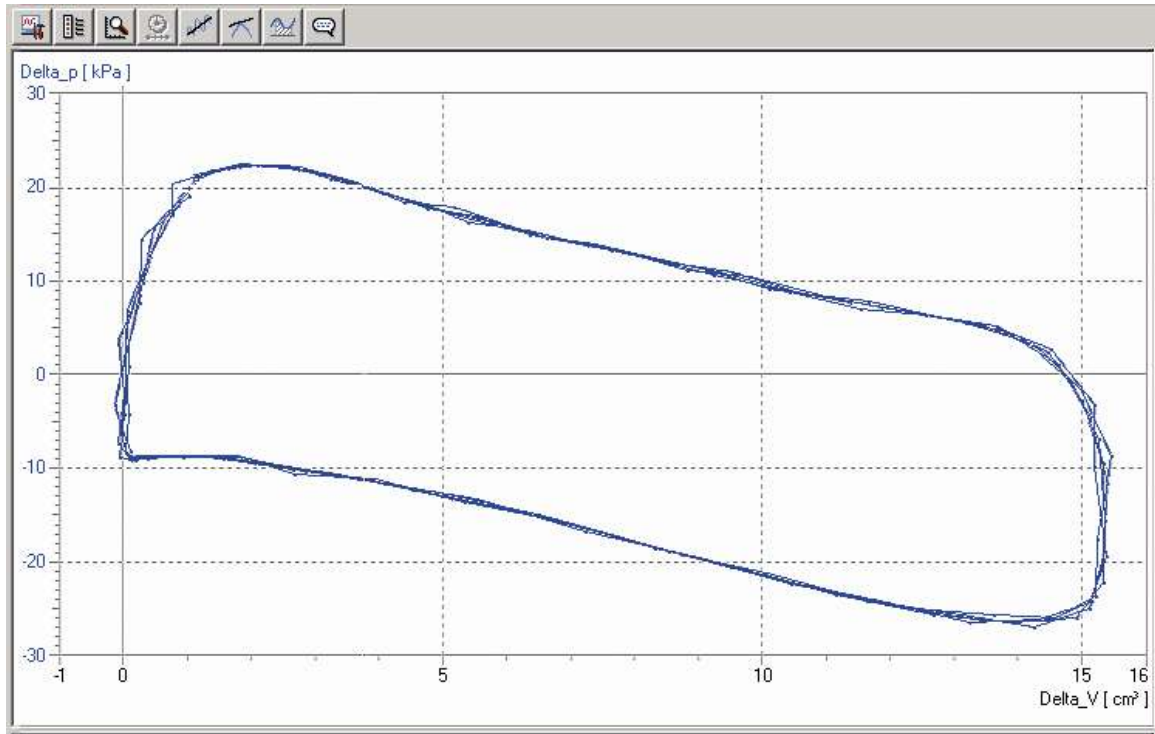

Fig. 10: Pressure-volume diagram for D-series Stirling engine