

Pendulum Rod with Angle Sensor

1000762 (115 V, 50/60 Hz)
1000763 (230 V, 50/60 Hz)

Instruction manual

10/15 ALF

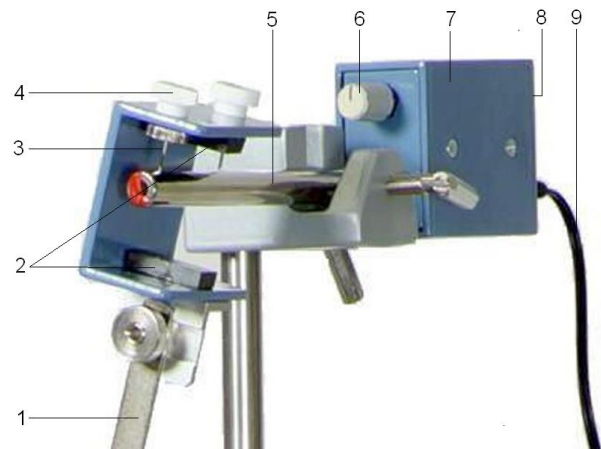
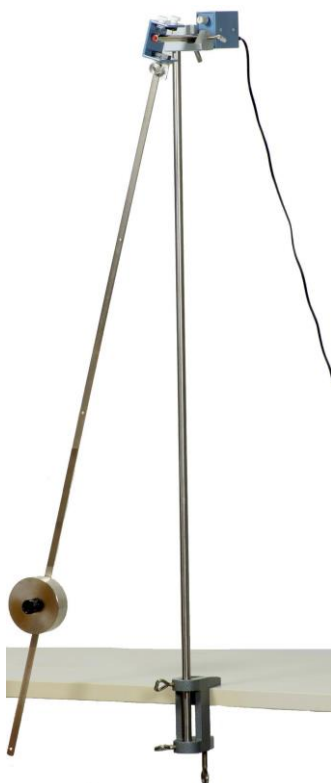

Bearing arrangement for rod pendulum with angle sensor (magnified detail)

- 1 Rod pendulum
- 2 Pair of magnets
- 3 Needle bearing
- 4 Adjustment screw
- 5 Bearing rod with built-in Hall sensor
- 6 Offset adjustment knob
- 7 Angle sensor
- 8 BNC socket (not visible)
- 9 Power supply lead

1. Safety instructions

Caution: The pendulum is equipped with a heavy bob and two sharp needle bearings, meaning there is a risk of injury.

- Make sure the pendulum is resting in a safe and secure location.
- The pendulum bob always needs to be secured against falling by means of the knurled screw.
- When setting up the pendulum, always make sure that both needle bearings are correctly situated in the groove.

2. Description

The rod pendulum with angle sensor is designed for investigating simple harmonic oscillations of a weighted pendulum. It is also possible to investigate coupled oscillations with the addition of a second pendulum and a coupling spring.

The pendulum consists of a flat rod with a U-shaped bracket into which two needle bearings are screwed. There are two permanent magnets on the inside of the bracket arms. The pendulum fits into a bearing rod with a V-shaped groove, which is attached to a stand rod by means of a universal clamp. The two points of contact for the needle bearings are indicated by circular

markings. Between these two markings, a Hall sensor is built into the bearing rod. It is aligned in such a way that field lines run in the direction of the chip when the pendulum is at rest, meaning that there is then no Hall effect detectable. An electronic module for sensing angle is screwed onto the bearing rod. This transducer detects the angle of deflection of the pendulum and converts it into an electric signal which is proportional to that angle. If the pendulum is deflected from the vertical by an angle δ , a horizontal field component arises, which results in a positive or negative output voltage depending on the direction.

A disc-shaped weight serves as the pendulum bob.

Power is provided via a 12-V AC plug-in supply which is included with the apparatus.

Rod pendulum 1000762 is designed for a mains voltage of 115 V ($\pm 10\%$), while 1000763 is designed for 230 V ($\pm 10\%$).

Note: The angle sensor is matched to the pair of magnets of the needle bearing such that the output voltage from the BNC socket is approximately zero in the rest position. Fine adjustment can be carried out using the offset adjustment knob. The arrangement of the needle bearing and the angle sensor is indicated by a number on the housings. If equipment with differing numbers is used, it may be that high offset voltages occur due to the scattering that results from the specific properties of the magnets.

3. Contents

1 Pendulum rod with U-shaped bracket and needle bearings
 1 Pendulum bob
 1 Bearing rod with V-shaped groove and angle sensor attached
 1 Plug-in power supply, 12 V AC

4. Technical data

Operating voltage:	12 V AC
Output voltage:	± 5 V
Output resistance:	500 ohms
Maximum length of pendulum:	1 m
Mass of pendulum bob:	1 kg
Weight of angle sensor:	0.3 kg approx.
Bearing rod:	10 mm diam.

5. Operation

The following additional equipment is required to set up the rod pendulum in order to carry out experiments:

For set-up:

1 Bench clamp	1002832
1 Stand rod, 1000 mm	1002936
1 Universal clamp	1002830

For measurement:

1 Computer	
1 USB oscilloscope 2x50 MHz	1017264
1 HF patch cord	1002746
or	
1 3B NET/log™ (230 V, 50/60 Hz)	1000540
or	
1 3B NET/log™ (115 V, 50/60 Hz)	1000539
1 3B NET/lab™	1000544
1 HF patch cord, BNC/4 mm plug	1002748

5.1 Set-up for rod pendulum

- To set up the rod pendulum, attach the stand rod to the bench in an upright position by means of the bench clamp.
- Attach the bearing rod to the stand rod at a suitable height by means of the universal clamp.
- Insert the needle bearings for the pendulum into their intended positions (marked by circles).
- If the bearing rod is not horizontal, then level it with the help of the adjusting screws.
- Move the pendulum bob along the rod to set up the effective length of the pendulum L and secure the bob with the knurled screw.
- Plug in the power supply to connect the angle sensor to the mains and connect it to a storage oscilloscope or a computer-based measurement system by means of the BNC socket.

5.2 Setting offset

- Turn on the oscilloscope or computer interface.
- If a value other than zero is read when the pendulum is in its rest position, you can use the offset adjustment knob to compensate.

5.3 Calibration of output voltage

In order to evaluate the experiment results quantitatively, it is necessary to know the precise relationship between the output voltage and the angle of deflection.

- Determine the angle of deflection geometrically with the help of a ruler (see Fig. 2) and match this with the corresponding output voltage.

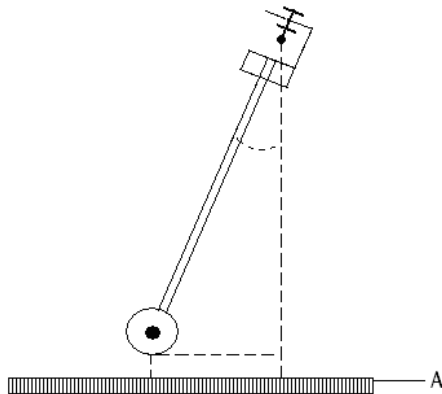

Fig. 1 Calibration of output voltage
A: Ruler

5.4 Coupled pendulums

To set up a coupled pendulum arrangement, it is necessary to use a second rod pendulum and a coupling spring.

The following equipment is needed:

2 Rod pendulums	1000764
1 Coil spring, 3.3 N/m	1002945
2 Bench clamps	1002832
2 Stand rods, 1000 mm	1002936
1 Stand rod, 470 mm	1002934
4 Universal clamps	1002830

- Set up both pendulums as described in step 5.1.
- You can increase the stability of the set-up by adding a short stand rod between the two long ones.
- Insert the ends of the coil spring into the holes in the pendulum rods to couple the two pendulums together.

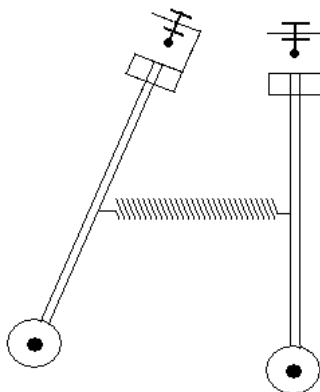

Fig. 2 Coupled pendulums

6. Disposal

- The packaging should be disposed of at local recycling points.
- Should you need to dispose of the angle sensor, never throw it away in normal domestic waste. Local regulations for the disposal of electrical equipment will apply.

