



EXPERIMENT PROCEDURE

- Measure the cut-off value of the decelerating voltage as a function of the wavelength of light
- Plot the results in a graph of energy against frequency.
- Determine Planck's constant and the work required to emit an electron.
- Demonstrate that the energy of the electrons does not depend on the intensity of the light.

OBJECTIVE

Determine Planck's constant using the decelerating voltage method.

SUMMARY

In a modified version of a classic set-up, light of known frequency passes through a ring-shaped anode to collide with a cathode, where it causes electrons to be released due to the photo-electric effect. The energy of the electrons can be determined by applying a decelerating voltage, which compensates for the flow of electrons towards the anode until no electrons are flowing. This demonstrates that the cut-off value of the decelerating voltage which corresponds to a current of zero is not dependent on the intensity of the light. The energy of the electrons is therefore similarly independent of intensity. By obtaining the cut-off voltages for light of varying frequency, it is possible to calculate Planck's constant.

REQUIRED APPARATUS

Quantity	Product	Number
1	Planck's Constant Apparatus (230 V, 50/60 Hz)	1000537 or
	Planck's Constant Apparatus (115 V, 50/60 Hz)	1000536



BASIC PRINCIPLES

The photoelectric effect exhibits two important properties, which were discovered in 1902 by *Lenard*. The number of electrons emitted from the cathode material as a result of the photoelectric effect is proportional to the intensity of the incident light. However, the energy is dependent on the frequency of the light and not on its intensity. In 1905, *Einstein* used a hypothesis based on the description of black body radiation discovered by *Planck* to explain this and thereby laid important foundations for quantum mechanics.

Einstein assumed that light propagates in the form of photons possessing energy proportional to the frequency of the light. If a photon of energy

$$(1) \quad E = h \cdot f,$$

$$h = 6.626 \times 10^{-34} \text{ Js} : \text{ Planck's constant}$$

strikes an electron inside the cathode material, its energy can be transferred to the electron, which is then emitted from the cathode with kinetic energy

$$(2) \quad E_{\text{kin}} = h \cdot f - W$$

The work W required for emission of the electron is a quantity which is dependent on the nature of the material, its value for caesium for example is approximately 2 eV.

In this experiment, the above relationship is used to determine Planck's constant h . Light of a specific frequency f passes through a ring-shaped anode and strikes a cathode, causing electrons to be released. The resulting current from cathode to anode is then measured using a nanoammeter and a decelerating voltage U_0 is applied in order to reduce the current to zero. The light from various LEDs is used. The spectrum of the respective components is sufficiently narrow that a distinctive wavelength λ can be assigned to each of them, from which the frequency can be obtained as follows:

$$(3) \quad f = \frac{c}{\lambda}$$

$$c = 2.998 \times 10^8 \text{ m/s}$$

The intensity of the light from the diodes can be varied between 0% and 100%, meaning that it is possible to investigate how the energy of the electrons depends on the intensity of the light.

EVALUATION

In each case, the current is compensated to a value of zero at the cut-off value of the decelerating voltage U_0 . This definition can be summarised using equations (2) and (3) as follows

$$e \cdot U_0 = h \cdot f - W = h \cdot \frac{c}{\lambda} - W$$

where $e = 1.602 \times 10^{-19} \text{ As}$: elementary charge

Planck's constant can therefore be determined from the slope of a graph where values $E = e \cdot U_0$ are plotted along the y-axis and values of $f = \frac{c}{\lambda}$ are plotted along the x-axis.

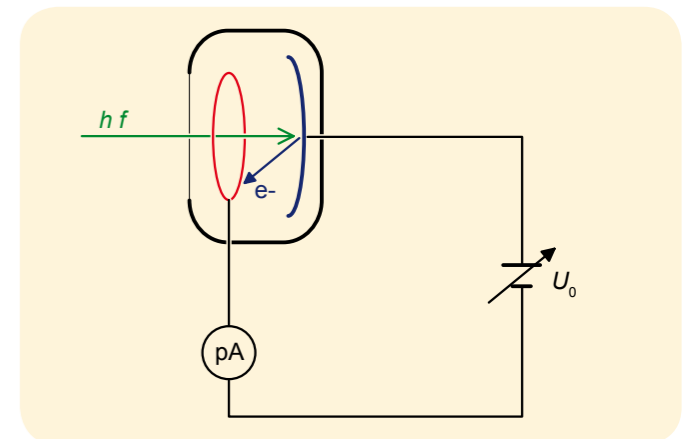

Fig. 1: Schematic of set-up for measurements

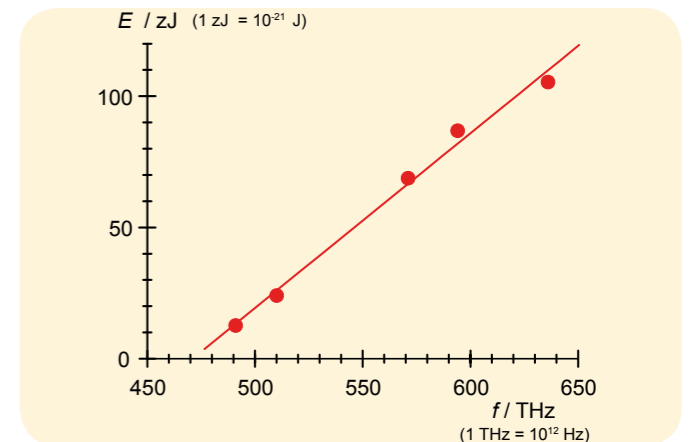

Fig. 2: Graph of energy against frequency

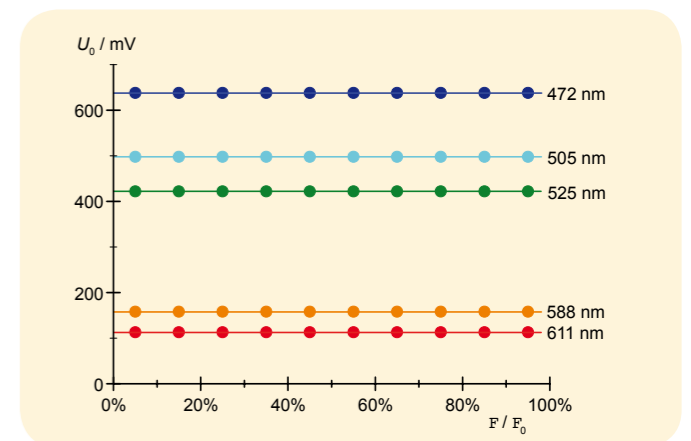

Fig. 3: Cut-off voltage U_0 as a function of intensity